

Solenoids

How to select your BLP Solenoid

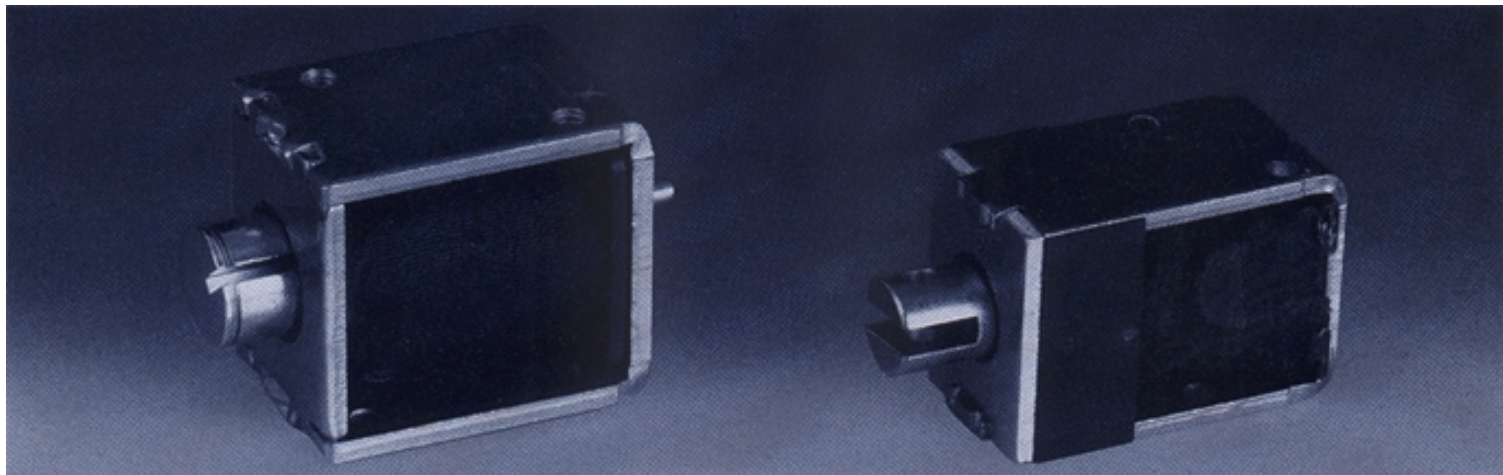

Description

Basically a solenoid consists of a coil with an associated iron circuit forming the fixed part. A moving iron plunger is pulled into this coil when it is energized.

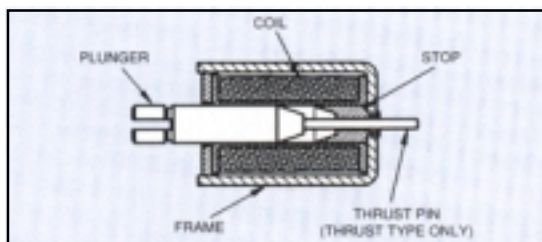

Pull and thrust

Most solenoids have a pull action. This pull action can be converted to a pushing action by fitting a suitable thrust pin or plunger extension.

AC or DC operation

Often the choice is predetermined by the supply available. Where there is a choice these factors should be considered.

- AC solenoids tend to be more powerful in the fully open position than DC. This is due to 'inrush current' which at maximum stroke can be more than ten times the closed current.
- AC solenoids must close completely so that the inrush current falls to its normal value. If an AC solenoid sticks in the open position a burn-out is likely. DC solenoids take the same current throughout their stroke and cannot overheat through incomplete closing.
- AC operated solenoids are usually faster than DC, but with a few milli-seconds variation in response time depending on the point of cycle when the solenoid is energized. DC solenoids are slower but they repeat their closing times accurately against a given load.

- A good AC solenoid correctly used should be quiet when closed, but only because it's fundamental tendency to hum has been overcome by correct design and accurate assembly. Dirt on the mating faces or mechanical overload may make it noisy. A DC solenoid is naturally quiet.

Voltage

Again this choice will normally be predetermined by the supplies available. A solenoid can be wound for any voltage between the limits of unreasonably fine wire for high voltages and wire too thick to handle for the very low voltages. Where a choice is available it should be remembered that a low voltage coil tends to give more power than one for high voltage, and is more robust as it uses heavier wire.

6, 12, 24V DC are standards. Other voltages are available as options.

110, 230V AC are standards.

Wattage - Temperature

All units in this catalogue are designed on the basis of a maximum allowable input wattage without exceeding a 105°C (221°F) stabilized coil temperature when operated at the rated duty cycle in a 20°C (68°F) ambient temperature.

Force/stroke curve

When a solenoid is fully opened it has a large air gap. The reluctance of this air gaps keeps the magnetic field small and the force correspondingly low. As the plunger closes, the reluctance falls and the magnetic field increases. For this reason, the force obtainable from a solenoid increases progressively as the plunger closes.

These curves show the force exerted with the coil at full working temperature. The force exerted by a cold solenoid is always higher. Force variations with temperature are greatest on DC solenoids.

See overleaf for typical curves.

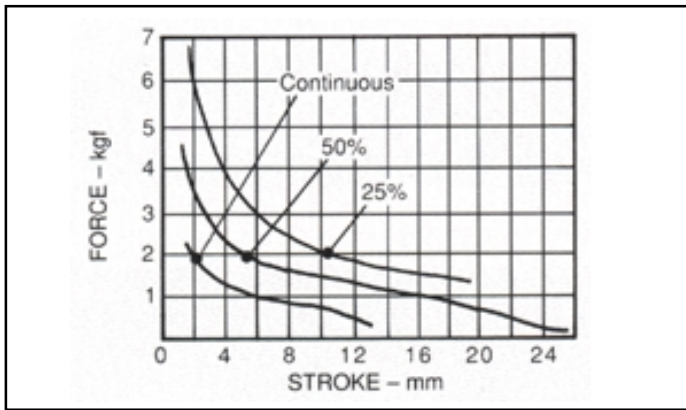

AC OPERATED (Typical)

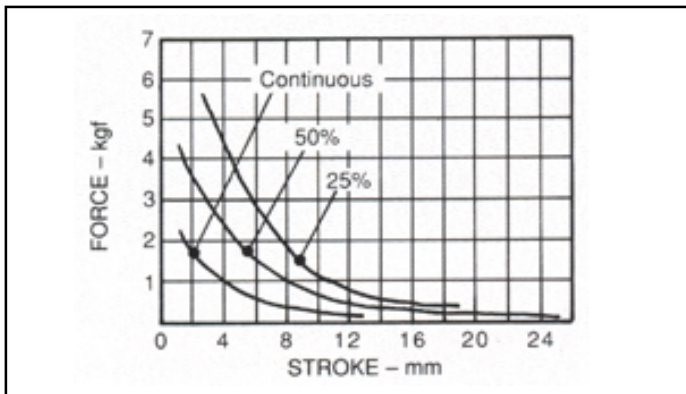

DC OPERATED (Typical)

Matching solenoid to load

The force/stroke curves give the nominal force that will be available from the plunger at any particular plunger position. There will also be a matching duty cycle which will be the force required by the solenoid's load throughout the stroke. In some cases this may be for practical purposes constant, as, for example, when a solenoid lifts a dead weight. In some cases, however, the mechanism may be spring loaded so that the force taken by the load is progressively greater as the plunger goes in. There may be cases when a solenoid is operating a number of linkages.

Operate time

At any point in the operating stroke the difference between the force available from the solenoid and the force required to drive the load will be the force available to accelerate the load and plunger. This means, of course, that the more excess power there is available from the solenoid the faster the solenoid will operate. The closing time of the solenoid is approximately doubled as its mechanical load is increased from 70% of what it will pull to the maximum. For reasonably fast operation 25% excess power is advisable. As a general principle, the use of excessively large solenoids for the duty is not, however, good practice, as unabsorbed energy must be taken up on impact.

Capacitor discharge circuits can be used to provide very fast closing while keeping the power in the hold position to a reasonable value.

Duty cycle

'Continuous Rating' means that the solenoid can be left on continuously without overheating. The force exerted and the power consumed are then the basic continuous rating values

to which all other ratings are referred. In the case of an AC solenoid the continuous rating refers to the solenoid in the closed position only. If the solenoid plunger is withdrawn, the 'inrush' current will rise to a high value; and if left energized, will burn out. A continuously rated DC solenoid can be left energized continuously, irrespective of the plunger position.

In many applications a solenoid is energized for only a short period and then left switched off for some time, so that it can cool down. Under these circumstances the solenoid coil can be wound for a much higher power than the continuous rating value. As a result, higher forces can be obtained with the proviso that the solenoid can no longer be continuously energized.

The definition is:
$$\text{Duty Cycle} = \frac{\text{"ON" pulse time}}{\text{"ON" + "OFF" pulse time}}$$

In the case of intermittent duty, higher forces can be obtained from a higher input power. The input power that can be applied is as high as the given wattage by:

Wattage =

$$\text{Wattage at 100\% duty} \left(\frac{\text{catalogue value}}{\text{value}} \right) \times \frac{100}{\text{Your Duty (\%)}}$$

If, for example, the catalogue shows 5 watts at 100% duty (continuous). 20 watts can be applied at 25% duty ($5 \times 100/25\% = 5 \times 4 = 20$)

Continuous (100%), 50%, 25% and 10% duty cycles are standard.

In some cases, solenoids may be required for intermittent operation, but not on a fixed time cycle. For guidance on this, the maximum 'on time' for the different ratings on a single cycle basis is given. This is the maximum time this particular solenoid can be left energized when starting from ambient temperature of 20°C.

When AC solenoids are used on fast cycling, 'inrush current' occurs at each closure. With fairly long cycle times where the solenoid closes and then remains energized for some time, the increase in power during the operate period has no significant effect. If the cycle time is fast, so that the solenoid barely has time to close before it is de-energized again, then the inrush current causes considerable extra heating effects. Fast cycling AC solenoids may require the use of continuously rated solenoids for intermittent duties.

Anti-residual springs

With low force applications plungers may hold in on residual flux. To prevent this anti-residual springs are available. The force stroke characteristics will be modified when the springs are fitted.

Return springs

In certain applications a spring may be fitted to the plunger in order to return the plunger to its original position.

Plunger end styles

Pull force characteristics depend on the iron core plunger end style.

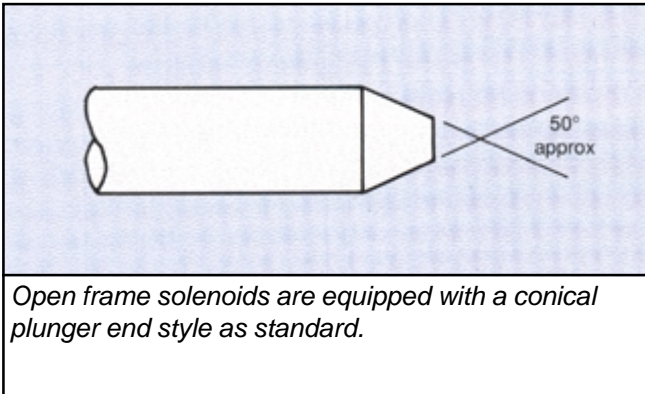

The pull/stroke curves in the open frame sections represent the performance achieved with the standard 40° to 55° conical plunger end style. This design is best suited for strokes greater than 2mm. Optional plunger end styles are available for shorter stroke lengths to achieve greater pull force.

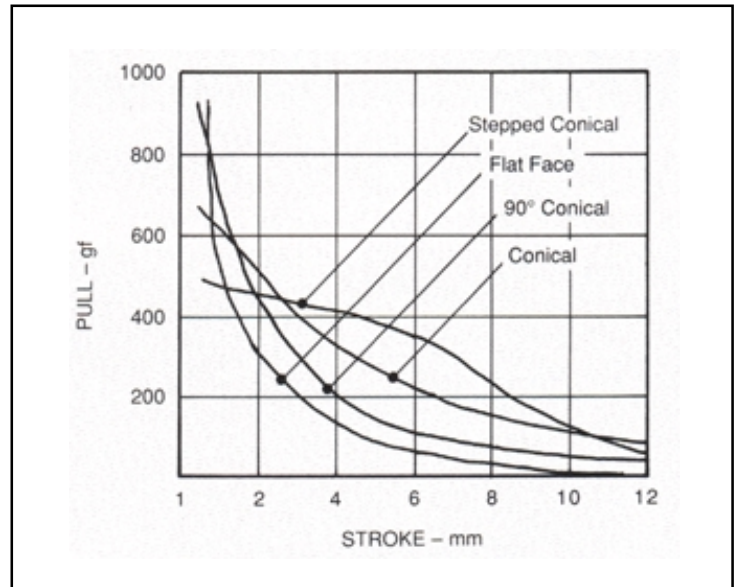

Plunger end styles Pull/Stroke comparison

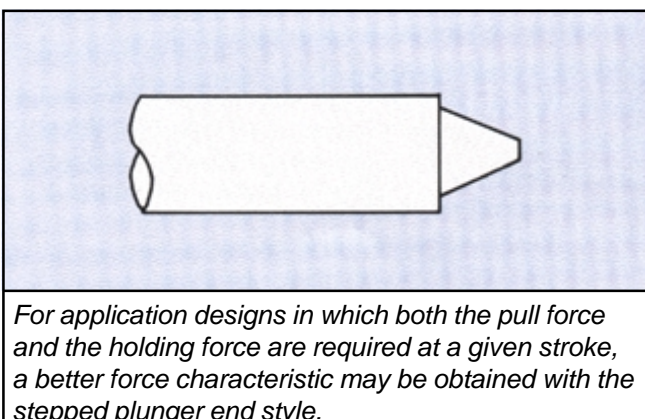
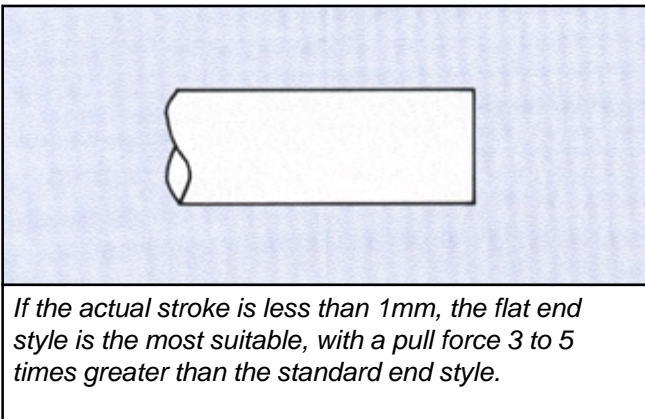
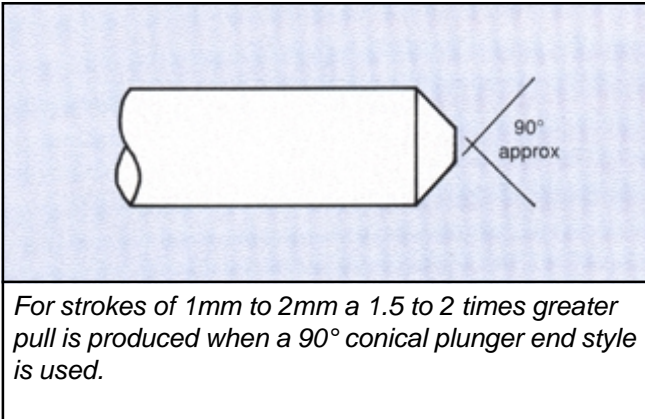

Typical plunger external end configurations

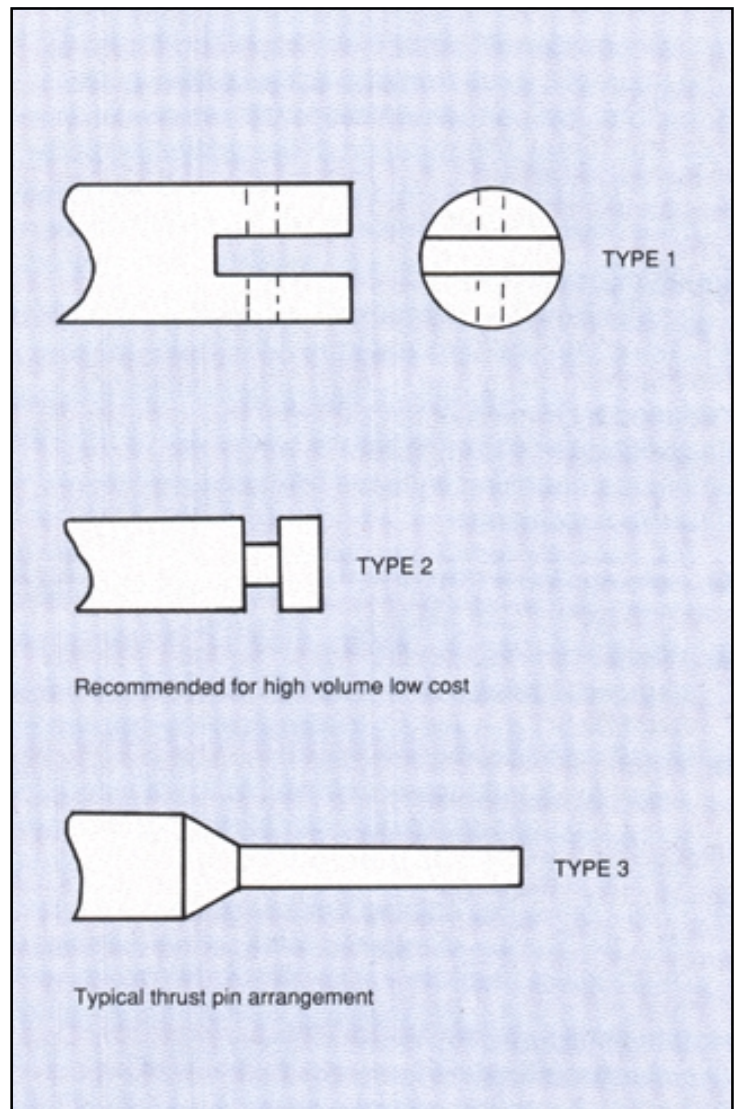

LATCHING SOLENOIDS

The latching solenoid series incorporate permanent magnets which provide the following benefits:

- No self heating.
- Continues to hold even after the power is disconnected
- Can operate by a pulse signal
- A charge/discharge of capacitor will be enough to set and reset.

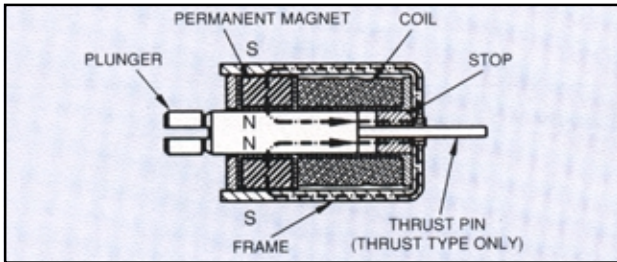

Pull operation

The action of the permanent magnets gives a small pull force with no power applied to the coil. This force increases significantly on very short strokes. The magnetic force from the coil is added to the force from the permanent magnets to increase the total pull force. The duration of the activating pulse depends on the solenoid size, stroke and/or amount of physical load. Normally 80-150ms is sufficient.

Release operation

The force from the permanent magnets is cancelled when the coil is energized in reverse polarity, and the plunger, being free from magnetic influence is released by means of the external mechanism. In this operation, it is important to apply the correct amplitude releasing voltage. The following factors must be considered:

- Holding Force (F_h) = Permanent Magnet Force (F_m) minus Coil Magnet Force (F_e)
- When $F_m > F_e$, holding force prevails. For the plunger to release the external mechanism force must be $> F_m - F_e$
- When $F_m = F_e$, there is no holding force and the external mechanism need only supply sufficient force to overcome effects of friction and/or gravity.
- When $F_m < F_e$, holding force is generated by the coil. For the plunger to release the external mechanism must be $< F_e - F_m$.

Holding Force of Permanent Magnets

The magnetic holding force values given for respective types are average initial values measured after application of rated voltage.

www.blpcomp.com
sales@blpcomp.com

Examples of correct releasing voltage

If the force from the external release mechanism is low and the reverse polarity pulse is high the solenoid plunger may not release even when voltage is applied in reverse polarity. There are two solutions to this condition - one is to reduce the releasing voltage, and the other to insert a resistor externally in series with the coil. The latter is the more commonly adopted method, and the resistor value is calculated as follows.

The relationship between external releasing force and releasing pulse voltage can be typically shown by the curve A-B-C-D in Fig 1, which is based on actual measurement. The correct releasing pulse voltage "Ex" and the external resistance "r" for the external releasing force "Wx" are:

$$Ex = \frac{e_2 - e_1}{2} + e_1 \text{ (V)}, \quad r = \frac{E}{Ex} R - R \text{ (ohms)}$$

where: e_1 = minimum releasing voltage
 e_2 = maximum releasing voltage
E = circuit voltage
R = coil resistance

EXAMPLE: On the type 67, when $W_x = 200\text{gf}$, $R = 29$ ohms, $e = 4.4$ VDC, $e_2 = 14.6$ VDC and $E = 24$ VDC, correct value of external resistor can be obtained from the following equations:

$$Ex = \frac{14.6 - 4.4}{2} + 4.4 = 5.1 + 4.4 = 9.5 \text{ (V)}$$

$$r = \frac{24}{9.5} \cdot 29 - 29 = 73.26 - 29 = 44.3 \text{ (ohms)}$$

The duration of releasing pulse depends on the inductance the coil and/or amount of the external releasing force. Generally, 30-60 ms is required.

A special type of winding having two coils, one for pull and the other for release operations respectively, is available upon request. One of the three terminals is used in common for both coils.

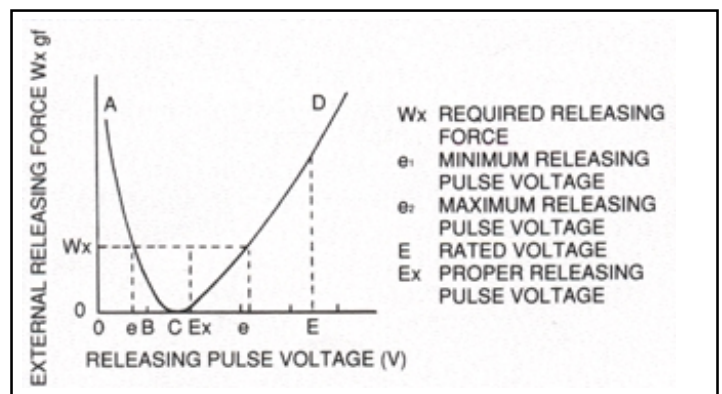

Relationship between releasing force and releasing pulse voltage